

# SFERA 54x35

**CATALANO**  
THE ESSENCE OF CERAMICS

cod. 1VSF54A00

Wc sospeso.  
Wall-hung WC.  
Wand-wc.

cod. 5KFST00

Kit fissaggio dal basso.  
Kit for bottom-side fixing.  
Kit für die Befestigung von unten.



 cod. 5SCSTP000 Soft Close Plus\*

 cod. 5SCSTF000 Soft Close\*

 cod. 5SCST000 Standard\*

 cod. 5ZECOF00 Soft Close\*

 EN 997 - CL1 - 5A



\* TakeOff System

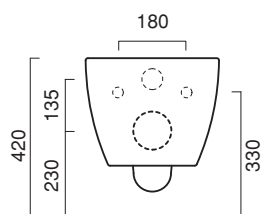
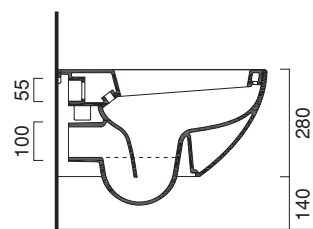
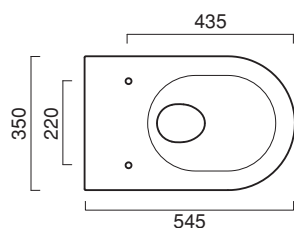

Tutti i diritti sulla presente scheda appartengono a Ceramica Catalano S.p.A. in via esclusiva. È vietata la copia, la pubblicazione, la distribuzione o la riproduzione (anche parziale), se non autorizzata per iscritto.  
All rights in the present form belong exclusively to Ceramica Catalano S.p.A. It is strictly forbidden to copy, publish, distribute or reproduce it (including any partial reproduction), without prior written permission.

MADE IN ITALY

## CATAglaze

È una barriera totale a prova di sporco. Creando una superficie liscia e planare, elimina i micro avvallamenti della ceramica, evitando per sempre alle macchie di aderire.

*Is a total bacteria-proof barrier. By creating a perfectly smooth and flat surface, it eliminates the micro-depressions of ceramics and does not allow dirt to stick on it anymore.*

*Cataglaze bildet eine schmutzabweisende Barriere. Dank der perfekt glatten und ebenen Oberfläche werden Vertiefungen in der Keramik beseitigt und dadurch das Anhaften von Schmutz und Kalk deutlich reduziert.*

## GARANZIA

Il rivenditore sostituirà i prodotti con difetti di fabbricazione entro due anni dalla consegna.

*Your retailer will replace products with faults of manufacturing within two years from delivery date.*

*Der Wiederverkäufer wird Produkte mit Fabrikationsfehlern innerhalb 2 Jahren seit Zustellung ersetzen.*

## PULIZIA

Si consiglia di pulire con acqua tiepida e detersivo non abrasivo.

*The maintenance has to be done with tepid water and not abrasive detergents.*

*Für die Reinigung empfiehlt sich lauwarmes Wasser und keine Scheuermittel zu verwenden.*

## DICHIARAZIONE DI PERFORMANCE - DOP N° 997

Scarica il documento al seguente link a lato:

*Click the link on the side to download the document:*

*Klicken Sie auf den Link zum Herunterladen des Dokuments:*

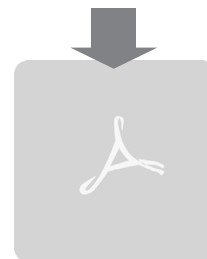

## WATER LABEL

Una nuova etichetta informativa accompagna i WC Catalano, attribuita e certificata dalla The Water Label Company. L'etichetta mostra una classificazione di performance, indicando il volume massimo d'acqua che il wc utilizza nella fase di scarico.

*All Catalano WCs have a new label, certified and issued by The Water Label Company. The label shows a performance ranking, indicating the maximum water volume of the toilet's flush.*

*Die Catalano-WCs besitzen eine neue Zertifizierung, die von der Water Label Company vergeben wird. Die Zertifizierung stellt eine Leistungsklassifizierung dar und gibt das maximale Wasservolumen an, das ein WC bei der Spülung verbraucht.*

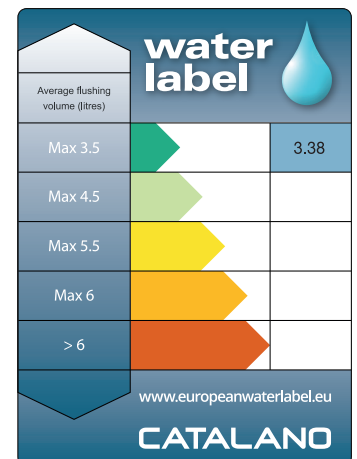

## KIT DI FISSAGGIO

Installabile esclusivamente su barre m 12 e con apposito kit di fissaggio dal basso.

*For m 12 threaded bars only use proper bottom-side fixing sets.*

*Nur auf barren m12 mit dafür vorgesehenem Befestigungsset installierbar.*

vedi il video al seguente link a lato:

*Click the picture on the right to watch the video:*

*Klicke auf das Bild rechts, um das Video anzuschauen:*

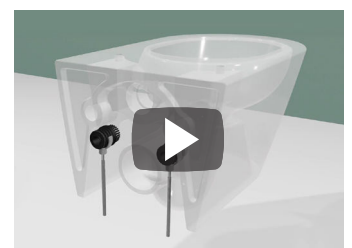

# SFERA 54x35

**CATALANO**  
THE ESSENCE OF CERAMICS

cod. 1BSF5400

Bidet sospeso monoforo.  
Wall-hung single-hole bidet.  
Einloch-Hängebidet.

cod. 5KFST00

Kit fissaggio dal basso.  
Kit for bottom-side fixing.  
Kit für die Befestigung von unten.



**CE** EN 14528 - CL20

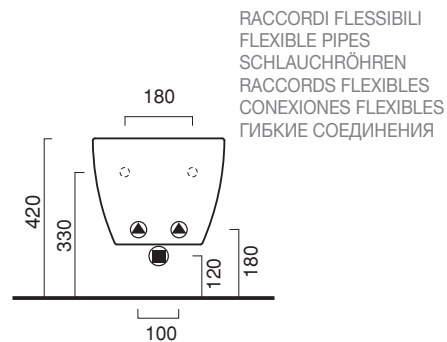
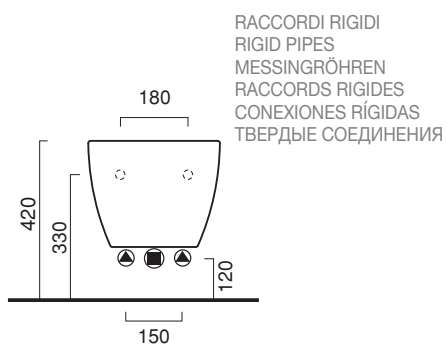
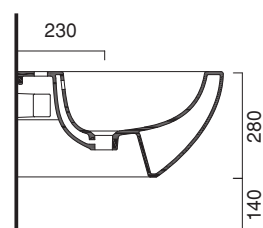
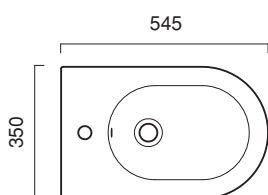

Tutti i diritti sulla presente scheda appartengono a Ceramica Catalano S.p.A. in via esclusiva. È vietata la copia, la pubblicazione, la distribuzione o la riproduzione (anche parziale), se non autorizzata per iscritto.  
All rights in the present form belong exclusively to Ceramica Catalano S.p.A. It is strictly forbidden to copy, publish, distribute or reproduce it (including any partial reproduction), without prior written permission.

MADE IN ITALY

## CATAglaze

È una barriera totale a prova di sporco. Creando una superficie liscia e planare, elimina i micro avvallamenti della ceramica, evitando per sempre alle macchie di aderire.

*Is a total bacteria-proof barrier. By creating a perfectly smooth and flat surface, it eliminates the micro-depressions of ceramics and does not allow dirt to stick on it anymore.*

*Cataglaze bildet eine schmutzabweisende Barriere. Dank der perfekt glatten und ebenen Oberfläche werden Vertiefungen in der Keramik beseitigt und dadurch das Anhaften von Schmutz und Kalk deutlich reduziert.*

## GARANZIA

Il rivenditore sostituirà i prodotti con difetti di fabbricazione entro due anni dalla consegna.

*Your retailer will replace products with faults of manufacturing within two years from delivery date.*

*Der Wiederverkäufer wird Produkte mit Fabrikationsfehlern innerhalb 2 Jahren seit Zustellung ersetzen.*

## PULIZIA

Si consiglia di pulire con acqua tiepida e detersivo non abrasivo.

*The maintenance has to be done with tepid water and not abrasive detergents.*

*Für die Reinigung empfiehlt sich lauwarmes Wasser und keine Scheuermittel zu verwenden.*

## DICHIARAZIONE DI PERFORMANCE - DOP No 14528

Scarica il documento al seguente link a lato:

*Click the link on the side to download the document:*

*Klicken Sie auf den Link zum Herunterladen des Dokuments:*

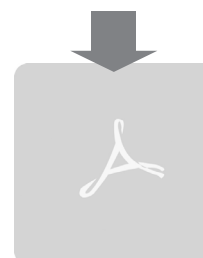

## KIT DI FISSAGGIO

Installabile esclusivamente su barre m 12 e con apposito kit di fissaggio dal basso.

*For m 12 threaded bars only use proper bottom-side fixing sets.*

*Nur auf barren m12 mit dafür vorgesehenem befestigungsset installierbar.*

vedi il video al seguente link a lato:

*Click the picture on the right to watch the video:*

*Klicke auf das Bild rechts, um das Video anzuschauen:*

